

SAS and the Market Overview

Serial Attached SCSI (SAS), the successor technology to the parallel SCSI interface, leverages proven SCSI functionality and features while expanding SCSI's proven performance, scalability and reliability for enterprise storage. SAS offers many features not found in today's mainstream storage solutions such as drive addressability up to 16,000 devices per port, and reliable point-to-point serial connections at first-generation speeds of up to 3 Gb/sec. In addition, SAS's small connector supports full dual-ported connections on 2.5-inch hard disk drives, a feature previously found only on larger 3.5-inch Fibre Channel disk drives. Dual-ported connections are essential for applications that require redundant drive connections in a dense server form factor such as blade servers.

INTRODUCTION TO SERIAL ATTACHED SCSI (SAS)

Today's predominant server storage interface standards rely on parallel transmission of data streams for device-level attachment. However, parallel technology's signal skew and crosstalk, signal termination restrictions, cable and connector reflections, and device addressability, stand as barriers to throughput performance as servers are pushed to meet advancing system and application capabilities and requirements.

The market for storage solutions is changing dramatically. Digital media, email, e-commerce, and new government regulations are driving huge increases in information requirements for businesses of all sizes. From transaction-intensive applications to nearline storage of data that must be accessible 24x7, the latest data applications are not only changing the way storage is used, they are outstripping the capability of the parallel SCSI technology that has been the industry standard for reliable storage and connectivity for the past 20 years.

Parallel SCSI Technology

For the past 20 years, parallel SCSI has been the most widely deployed storage interface in server and storage data centers. While parallel SCSI has been a reliable standard interface, the technology has reached its highest performance level with the advent of Ultra320. ***As servers are pushed to meet advancing system and application computing requirements, parallel SCSI has had to contend with signal skew and crosstalk, signal termination restrictions, cable and connector reflections, and device addressability – all of which have become barriers to next-generation throughput performance.*** The industry leaders in server and storage computing have been working together in various consortiums to overcome this throughput performance challenge. The result of the intensive investigation has resulted in transitioning parallel SCSI to a serial interface.

Serial Technologies

Serial technology transmits data in a single stream instead of the multiple streams found in parallel technology, therefore it is not tied to a particular clock speed and can transfer data at a much higher rate (up to 30 times faster) than parallel technology. It also offers greater reliability and scalability.

Serial technology is not new. In fact, the SCSI evolution discussion was based on proven technical theory, by serial networks already deployed in the datacenter. In the late 1990's, storage utilization and growth was a critical issue facing the datacenter. The result was proposals and products that aggregated storage on a dedicated 'storage network'. This helped IT managers to consolidate and effectively manage and grow their aggregated enterprise data pools. To successfully implement this concept, the market required a technology that provided long distance support, since storage would now be consolidated away from a server, as well as high speed with minimal latency to provide rapid access to critical information. The result was the first serial technology to gain significant momentum in the mainstream enterprise marketplace, Fibre Channel.

Serial Attached SCSI is the logical evolution of the traditional SCSI interface, and it represents the continuation of more than 20 years of technology development and infrastructure investment. In Serial Attached SCSI, the SCSI protocol is transported over a serial interface. Compared to the existing SCSI interface, Serial Attached SCSI enables faster device interconnect speeds, simpler cabling and improved system reliability, while preserving existing SCSI capabilities. Serial Attached SCSI also improves connectivity to larger numbers of drives via a new type of device called an Expander. An Expander is an optional portion of Serial Attached SCSI and it enables one or more Serial Attached SCSI host controller ports to connect to a large number of drives. Each Expander allows connectivity to 64 ports, which may include host connections, other Expanders, or hard drives. Serial Attached SCSI consists of three distinct protocols, each transporting different information over the serial interface:

- Serial SCSI Protocol (SSP) maps the SCSI protocol
- Serial ATA Tunneled Protocol (STP) passes through Serial ATA commands
- SCSI Management Protocol (SMP) provides management information

Figure 1 illustrates how the three Serial Attached SCSI protocols interact with existing high-level software applications. It shows a single port view of the protocol stack for simplicity but multiple ports are possible. The SCSI applications require no modification to work with Serial Attached SCSI. All three protocols share a compatible link, phy and physical interface. A system that requires compatibility between Serial Attached SCSI and Serial ATA must implement all three protocols. Serial Attached SCSI employs a common electrical and physical connection interface with Serial ATA that enables manufacturers, integrators and users to populate their systems with either Serial Attached SCSI or Serial ATA disks. This compatibility provides unprecedented choices for scalable server and storage subsystem configuration and deployment.

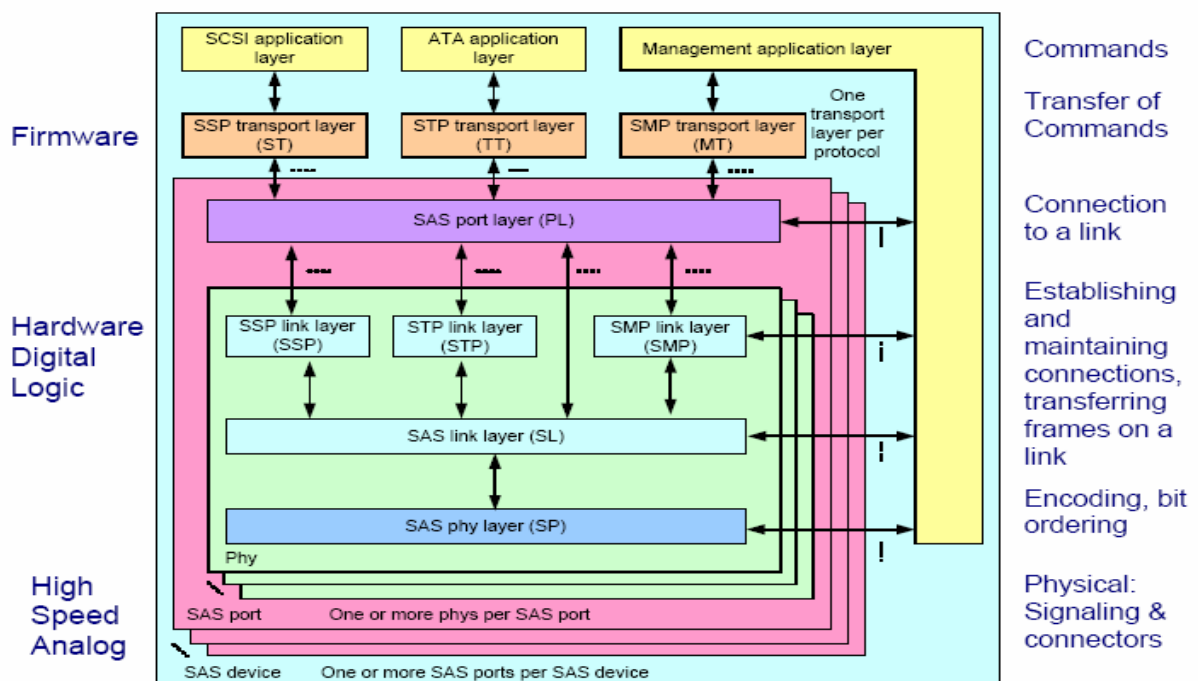

Figure 1; Serial Attached SCSI Multi-protocol Connection Support

SAS and SATA

Serial technology – SAS (Serial Attached SCSI) and SATA (Serial ATA) – was introduced to overcome these barriers, delivering greater speed, reliability and scalability. While SATA is designed for desktops, making it a good choice in storage environments requiring configuration simplicity or optimal cost/capacity, SAS delivers the high performance, scalability and reliability required for bandwidth-hungry mainstream servers and enterprise storage. SAS lends itself to the high frequency, immediate random data access required for transactional data applications such as online purchases and bank transactions.

Only SAS combines the proven reliability and functionality of SCSI with the performance and design power of serial technology by delivering the follow features and capabilities:

Performance – First-generation performance of up to 3Gb/s (300 megabytes/second), wide ports for aggregated bandwidth, full duplex, port aggregation, advanced command queuing and the rich command feature set of SCSI.

A SAS connection on a JBOD system can support a theoretical maximum of 1,200MB/s (see **Figure 2**). SAS is also used as a high performance, yet cost effective expansion port to daisy chain to another SAS subsystem.

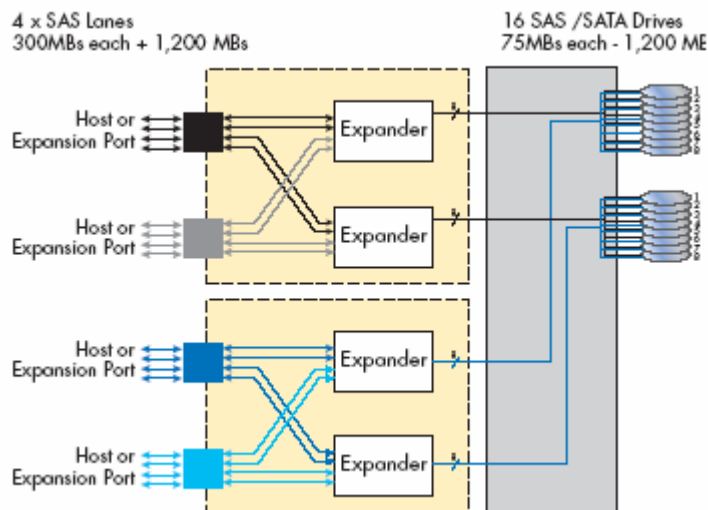

Figure 2

In addition, each 3Gb/s high-performance SAS drive (10K rpm or 15K rpm) is connected to a 3Gb/s drive connection, providing more than enough bandwidth for the highest performing drives (see **Figure 2**). Assuming 16 SAS drives in a subsystem and each drive capable of 75MB/s, that would equal 1,200 MB/s performance from 16 drives which far surpasses both 2Gb Fibre Channel loops and U320 Parallel SCSI buses. The roadmap for SAS is robust and provides clear investment protection by starting at 3Gb, doubling to 6Gb in 2008 and then doubling again to 12Gb.

Scalability – Broad address range to physical devices, long cables with small connectors, and connectivity to external storage systems

Reliability and Availability – Point-to-point connections, multi-initiator capability through expanders for simultaneous access, dual active port support, and redundant paths to targets

Flexibility – Physical and software compatibility with SAS and SATA drives, and backward compatibility with SCSI software and middleware

What is Serial Attached SCSI?

Finally, the most pervasive enterprise technology has come to a crossroads. Parallel SCSI is the heart of the datacenter – used as the standard interconnect and hard drive communication scheme for server and storage environments. Companies had been developing and utilizing SCSI for over 20 years as the mainstay for enterprise storage, but the technology's future was coming into question. Quite simply, the parallel interface would have to be overhauled to address next generation concerns of signal integrity, performance and reliability, right down to fundamentals like cable length. The result of three years of industry discussions and technological investigation is Serial Attached SCSI (SAS), the next standard in enterprise server and storage technology. SAS is a high-performance solution that leverages proven SCSI functionality, and builds on the enterprise expertise of multiple chip, board, drive, subsystem, and server manufacturers throughout the industry. It provides better performance and flexibility than the serial technology, Fibre Channel, at a lower cost and with the same, or ever better, reliability.

Key SAS Features Include:

- SAS and SATA drive support provides customers an unprecedented level of choice in the enterprise – the flexibility of integrating either SAS and/or SATA devices in common server or storage solutions, providing customization to meet cost or performance needs in customers' unique environments
- Reliable point-to-point connections at 3Gb/s – or 16,256 addressable devices in a per port
- Full dual-ported connections for performance or failover capabilities, delivering robust data protection and reliability right to the hard drive
- Enterprise features including native command queuing, support for LUNs greater than 2TB
- Available in multiple hot swappable disk drive performance and form factor configurations including high value 3.5" 10k rpm drives, high performance 3.5" 15k rpm drives and emerging 2.5" high density drives for performance server and specialized high performance storage applications
- Thinner cabling than SCSI and ATA which delivers new cooling metrics and more efficient airflow – critical in a dense computing environment where low profile servers are racked and stacked with multiple external storage chassis. Effective heat management and cooling schemes remain a top priority for IT managers today, delivering enhanced uptime and reliability guarantees in application sensitive environments

SAS delivers the high performance, scalability, and reliability required for bandwidth-hungry mainstream servers and enterprise storage. SAS lends itself to the high-frequency, immediate random data access required for transactional data applications such as online purchases and bank transactions and provides the performance and security required for mission-critical applications which demand data redundancy.

Serial Attached SCSI Market Overview

Today, in the \$13 billion storage marketplace, three dominant technologies account for the lion's share of sales: SCSI, Fibre Channel, and SATA.

As shown in **Figure 3**, current technology requires the use of different hard disk types to meet the needs of the common range of applications. Each hard disk type must use a controller with the same interface type. For example, a high-end performance system based on Fibre Channel disk drives requires a Fibre Channel controller interface. Some Fibre Channel deployments are Storage Area Networks (SANs) in which large data centers have deployed a dedicated high speed network and require dual redundant paths right to the hard drive to ensure reliability and performance. An affordable low-end SATA storage solution requires both SATA hard disks and a controller with a SATA interface. This inflexibility limits your choice in solutions and forces tradeoffs in your storage, such as performance and cost.

Storage Connectivity Market Today

Applications	Disk Drive Type
High-end	Fibre Channel
Mid-range	SCSI
Low-end	SATA

Figure3: Today, applications are addressed by specific drive types.

In contrast, SAS will become a nearly universal interface, dramatically changing the storage landscape and dominating market share and revenues. As shown in **Figure 4**, SAS will give you new, more cost-effective performance options for the high-end applications currently dominated by expensive Fibre Channel solutions. A SAS backplane also supports SATA disk technology, allowing you more flexibility in the solutions you can fit into one common storage enclosure. It also provides investment protection: start with low-cost SATA drives, then migrate to SAS drives as needs change, for Fibre Channel comparable performance in the same enclosure. In fact, for many business solutions, SAS allows you to more finely tune the relationship between performance and price point while dramatically simplifying overall system management. The transition from parallel SCSI and Fibre Channel technologies to SAS is starting right now, with SAS being integrated into solutions that will be ramping in 2006. In fact, SearchStorage has forecast that this year SAS will become the hottest direct attached storage (DAS) connection technology. Quite simply, by the end of 2006, SAS will be the industry's fastest growing storage technology.

SAS Impact on Storage Connectivity

Applications	Disk Drive Type
High-end	Fibre Channel
Mid-range	SCSI
Low-end	SATA

} SAS

Figure 4: SAS gives you new flexibility to choose the drive performance requirements needed at any point-in time at a price point that makes sense for your budget.

Conclusion

Over the past three years, Serial Attached SCSI (SAS) has been unveiled as the next evolution of the SCSI standard – featuring increased performance, scalability, and reliability, while maintaining ease-of-use and the SCSI feature set that has made SCSI the de facto standard in enterprise computing environments. The first SAS products are becoming available, and represent the first step in making SAS a widely adopted technology standard.

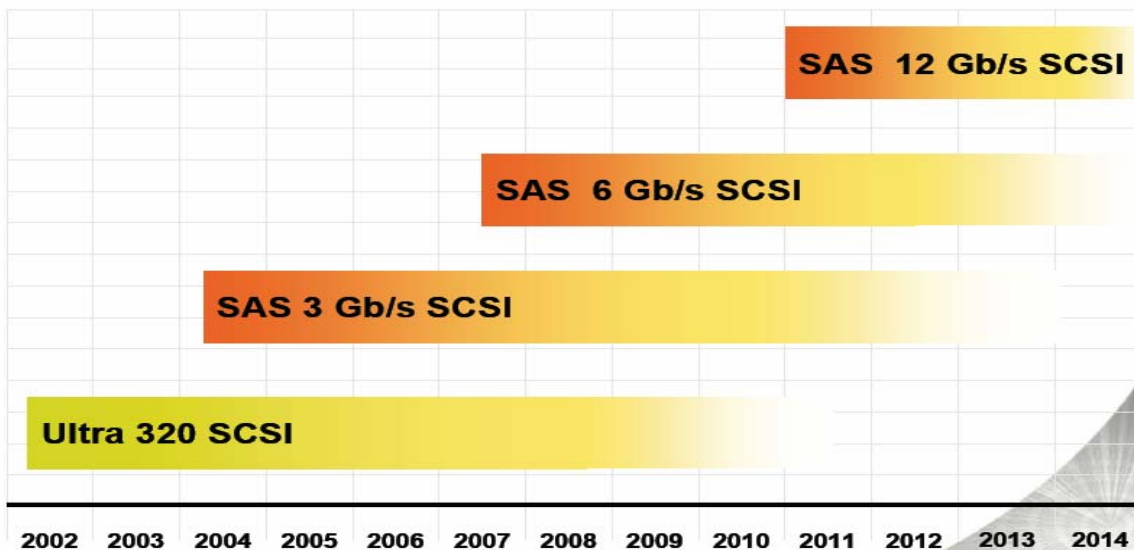

Figure 5: SAS will become the technology of choice for most storage needs, while coexisting with FC and SATA for very high end, or very cost-conscious requirements.

For the foreseeable future, Fibre Channel, SATA, and SAS will co-exist (as shown in **Figure 5**), with SCSI, SATA, and Fibre Channel addressing the left and right ends of the spectrum. Although full adoption of the SAS technology will not occur overnight, it is going to become the pervasive connectivity technology in the \$13 billion dollar storage marketplace. So, even though you may not be ready to switch to **Xtore** SAS just yet, it is to your advantage to start preparing for this transition.



SAS Roadmap



www.scsita.org